

ECONOMY SPREADER BEAM W/ MAGNETIC LIFTERS - SBM-10-12-ML

APPROX WEIGHT: 211.60 lbs.
DOES NOT INCLUDE WEIGHT OF POWER OR PACKAGING!!!

*** ANY ADDITIONS, DELETIONS, OR OMISSIONS MUST BE CORRECTED ON THIS DRAWING AS THIS DRAWING WILL BE CONSIDERED ALL INCLUSIVE ***

ALL GRAPHICS PROVIDED ARE FOR REFERENCE ONLY. IF CERTAIN DIMENSIONS ARE CRITICAL PLEASE VERIFY THOSE DIMENSIONS WITH YOUR SALESPERSON

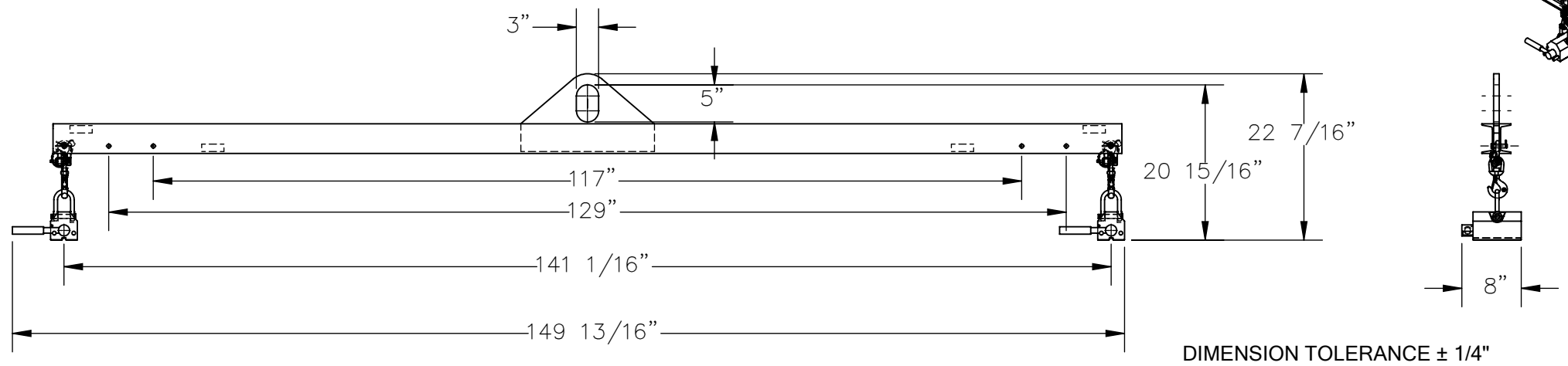
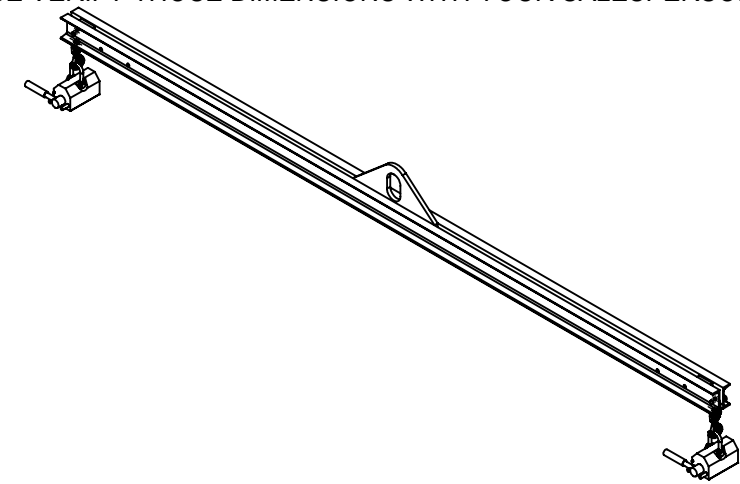

STANDARD FEATURES

- MODEL NUMBER IS SBM-10-12-ML
- OVERALL WIDTH IS 8"
- OVERALL HEIGHT IS 22 7/16"
- OVERALL LENGTH IS 149 13/16"
- USABLE BAIL IS 3"x5"
- MINIMUM SPREAD IS 117"
- MAXIMUM SPREAD IS 141 1/16"
- HEADROOM IS 20 15/16"
- MAX UNIFORM FLAT CAPACITY IS 1000 LBS.
- MAX UNIFORM ROUND CAPACITY IS 400 LBS.
- SPREADER BEAM TOUGH BAKED IN POWDER COAT BLUE FINISH
- MAGNET LIFTERS TOUGH BAKED IN POWDER COAT YELLOW FINISH

SPECIAL FEATURES

NONE

| | | |
|-----------------|--|-------------|
| APPROVAL | I, THE UNDERSIGNED, AGREE THAT THE PRODUCT AS REPRESENTED SATISFIES DESIGN AND DIMENSION REQUIREMENTS. I ALSO ACKNOWLEDGE MY DUTY TO CONFIRM PRODUCT AND INSTALLATION COMPLIANCE WITH ALL APPLICABLE FEDERAL, STATE AND LOCAL REGULATIONS AND STANDARDS. | |
| | ANY MODIFIED UNITS ARE NON-RETURNABLE | |
| | [] As drawn [] As marked | |
| | Signed: _____ | Date: _____ |

Printed Name: _____
LEAD TIME WILL START UPON RECEIPT OF SIGNED APPROVAL DRAWING

| | |
|---|--|
| FOR INTERNAL USE ONLY PROJECT SIGN OFF | |
| SALES | |
| ENG. | |
| FAB. | |
| POWER | |

| | | |
|----------------------|-------------|------------|
| DISTRIBUTOR'S NAME: | | P.O.# |
| VESTIL MANUFACTURING | | X |
| DRAWN BY: JGP | | W.O.# |
| DATE: 03/30/2020 | | X |
| REFERENCE: X | SCALE: 1:20 | SALES: X |
| QUOTED LEAD TIME: X | QUOTE # | FILE NAME: |
| | X | 08-007-450 |